

Instructions

These instructions will familiarize you with our STANDARD BREWING PROCEDURES of the Mr.Beer® Home Brewing System. Each recipe will produce about 2 gallons of our standard beer (approx. 3.7% abv) in as little as 14 days.

Once you are familiar with the basic principles of this brewing system, you will be able to make a wide range of other beers using this kit.

Premium/Deluxe Editions



Premium Edition Includes:

- (1) Brew Keg and Lid
- (1) Spigot, Washer and Nut
- (1) Hopped Malt Extract (HME)
- (1) Dry Yeast (under lid of HME)
- (1) Booster™
- (8) Plastic Bottles and Bottle Caps
- (8) Labels with MR.BEER® Logo
- (1) No-Rinse Cleanser
- (1) Brewing with MR.BEER® Book

Deluxe Edition Includes:

- (1) Brew Keg and Lid
- (1) Spigot, Washer and Nut
- (1) Hopped Malt Extract (HME)
- (1) Dry Yeast (under lid of HME)
- (1) Booster™
- (1) No-Rinse Cleanser
- (1) Brewing with MR.BEER® Book

NOTE: Premium Gold Edition includes an additional HME, Yeast, Booster™ and Cleanser

You'll need the following for each batch:

QTY	Items	Purpose
2	Gallons of cold water between 40°and 60°F	See step 2
1	1-Gallon container	See step 3
1	3-Quart pot (or larger)	See step 2
1	Metal spoon or whisk (DO NOT use wood or plastic)	See steps 1, 2 & 3
1	Can opener	See steps 1 & 2
1	Measuring cup/spoons	See steps 1, 2 & 3
1	Bowl or Plate	See step 1
-	Sugar (white granulated)	See step 3
-	Bottles with caps (Deluxe Edition users only)	See steps 3 & 4

Spigot Assembly

Place washer on the spigot so that its narrow edge faces the keg wall, then insert spigot into keg. Place the nut with the wide flat side against the keg wall and hand tighten.

DO NOT OVER TIGHTEN. FILL KEG AND TEST FOR ANY LEAKS.

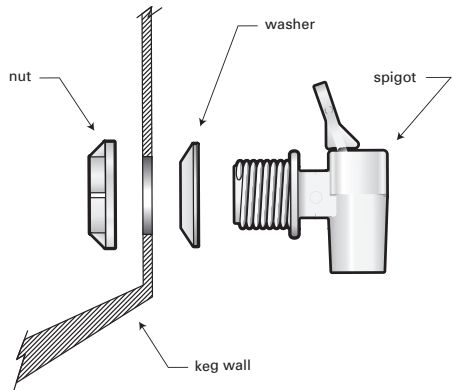

Step 1: Sanitizing

Sanitizing is an essential step in the brewing process because it kills microscopic bacteria, wild yeast and molds that may cause off flavors in your beer. YOU MUST SANITIZE ALL EQUIPMENT THAT COMES IN CONTACT WITH YOUR BEER.



1.1. Fill keg with lukewarm water to the 4-quart mark on the back. Then add 1/2 pack of No-Rinse Cleanser.

1.2. Screw on lid and swirl so that the solution makes contact with all parts of the keg, including the lid.

NOTE: DO THIS STEP OVER SINK. Keg has ventilation notches to release pressure during the fermentation process and will leak if tipped over.

1.3. Open and close the tap several times onto a bowl or plate in order to create a sanitized surface to place your utensils.

1.4. Place your metal spoon or whisk, can opener and measuring cup into the keg.

ALLOW ALL ITEMS TO SOAK FOR A MINIMUM OF 10 MINUTES.

1.5. Drain keg and remove all utensils, placing them on the sanitized bowl or plate. Rinsing is not required.

IF YOUR KIT DOESN'T INCLUDE BOTTLES -- Before it's time to bottle, collect enough PET plastic bottles (like empty soda bottles) to hold at least 256 fl oz. Any size bottle will work, but make sure you save the original caps. ONLY USE BOTTLES THAT PREVIOUSLY HELD CARBONATED BEVERAGES. Better yet, MR.BEER® sells a wide assortment of both plastic and glass bottles. For more information call (800) 852-4263 or visit our website at www.mrbeer.com.

Step 2: Brewing

Mixing your first batch should take about 30 minutes, but it isn't beer until the yeast does its part. If you keep your fermenting beer between 68° and 76° F the yeast will stay happy, and should finish within about 7 days.



2.1. Fill keg with cold water to the 4-quart mark on the back. (Avoid using water that tastes bad, or has been treated by reverse osmosis or a water softener.)

TIP: For best results, use bottled spring water or charcoal-filtered tap water between 40° and 60° F.

2.2. Remove yeast packet from under lid of HME, then place unopened can in hot tap water (warm liquid pours more easily).

2.3. Using the sanitized measuring cup, place 4 cups of water into a clean 3-quart pot, then SLOWLY sprinkle in Booster™ while continually stirring to avoid clumping.

2.4. Once the Booster™ is fully dissolved, bring to a boil, then remove from heat.

2.5. Stir HME into mixture of water and Booster™ (this mixture is called the wort).

2.6. Pour wort into keg. Bring the volume of the keg to the 8.5-quart mark by adding more cold water. Stir vigorously to mix well.

2.7. Sprinkle the yeast into your keg, WAIT 5 MINUTES, then stir vigorously and screw on lid (this is called pitching the yeast and begins the fermentation process).

2.8. Place keg out of direct sunlight, in a location with a consistent temperature between 68° and 76° F.

ALLOW TO SIT A MINIMUM OF 7 DAYS, 14 DAYS FOR BETTER FLAVOR.



CAUTION: DO NOT OPEN THE BREW KEG LID AT ANY TIME DURING THE FERMENTATION PROCESS; THIS CAN CAUSE BEER SPOilage.

Step 3: Bottling & Carbonating

Your beer is ready to bottle when the liquid in the keg is relatively clear and no longer cloudy. Not sure? Draw a small amount from the tap; if it tastes like flat beer, it's ready to bottle. If it tastes sweet, give it another day or two.



3.1. Fill a 1-gallon container with warm water and the remaining No-Rinse Cleanser. Using that container fill each bottle halfway. Screw on caps and shake bottles vigorously. Let soak for 10 minutes, then empty.

TIP: Do not unnecessarily move your keg while bottling; this will minimize amount of sediment transferred into the bottles.

3.2. Add white granulated sugar to bottles in the amounts shown below:

BOTTLE SIZE	SUGAR AMOUNT
12 OUNCES	3/4 tsp.
16 OUNCES	1 tsp.
20 OUNCES	1 1/4 tsp.
22 OUNCES	1 1/2 tsp.
1 LITER/QUART*	2 1/2 tsp.
2 LITER	1 1/2 tbsp.
3 LITER	2 1/4 tbsp.

*Bottles included in most kits.

3.3. Using the tap, fill each bottle to just above the base of the neck (about 2 1/2 inches from the top). Hold the bottles at an angle to reduce aeration.

3.4. Cap your bottles, then invert several times until the sugar dissolves.

3.5. Place bottles upright and out of direct sunlight, in a location with a consistent temperature between 68° and 76° F.

ALLOW TO SIT A MINIMUM OF 7 DAYS, 14 DAYS FOR BETTER CARBONATION AND FLAVOR.

NOTE: MR.BEER® is naturally fermented; therefore, there will be yeast sediment at the bottom of the bottle which may cause your beer to turn cloudy if disturbed.



CAUTION: TOO MUCH SUGAR AND/OR BOTTLING YOUR BEER TOO EARLY MAY RESULT IN GUSHING OR BURST BOTTLES DUE TO OVER CARBONATION. TOO LITTLE SUGAR WILL RESULT IN A FLAT BEER.

Step 4: Conditioning

After your beer has carbonated it is ready to drink. However, to improve the flavor of your beer even more, you may want to condition it for weeks or even months. This can be done in one of two ways:



A. Warm conditioning: Place bottles in a dark, dry location away from sunlight that stays between 50° and 70° F.

B. Cold conditioning: Place bottles in a refrigerator or dark, dry location that stays between 35° and 49° F.

Whether you choose to condition or not, your beer will always taste best if chilled for at least two days before drinking.

TIP: Drink within 4 months of bottling. Stronger and more hoppy beers will keep longer.

Care & Cleaning

The MR.BEER® keg, caps and bottles are completely reusable. With proper care, your brewing equipment will last for years. Follow these general maintenance tips for a long, successful brewing career:

- Thoroughly wash and rinse your keg and bottles immediately after use. Dried beer and/or yeast is much more difficult to remove.
- The plastic keg and bottles are not a dishwasher safe. Clean all plastic parts with mild, unscented soap (not dish soap) in warm water using a soft cloth.
- Disassemble spigot assembly between uses and wash in warm soapy water.
- Take care not to scratch the inside of your brew keg. Avoid using scouring pads, wire brushes, or abrasives during cleaning.
- Discontinue the use of any equipment that is scratched or cracked. Even small defects can harbor bacteria that might spoil your beer.
- Just before brewing your next batch, make sure to sanitize all your brewing equipment according to the instructions.

WARRANTY INFORMATION

MR.BEER® guarantees all products to be free from defects in materials and workmanship at the time of purchase. If you find the product to be defective please call **(800) 852-4263** or email customerservice@mrbeer.com and we will work with you to resolve the issue to your satisfaction.

RETURN POLICY

Please do not return the product to the place of purchase; doing so may delay the processing of your claim or replacement of your product. If you are dissatisfied with your purchase for any reason call **(800) 852-4263** and we will work with you to resolve any issue. All returns require a return authorization number.