

Artful
WINEMAKER
PERSONAL WINEMAKING SYSTEM

WINEMAKING INSTRUCTIONS



CREATING 12 BOTTLES OF SIGNATURE WINE
HAS NEVER BEEN SIMPLER

DISCOVER THE WINEMAKER IN YOU

Your premium wine kit should contain the following:

One (1) bag of grape juice and three (3) packages (Day 1, 14 and 28)

- Capsules (12)

Package 1 – Day 1

- #2 – Primary Wine Clarifier
- Yeast
- Cleanser
- May contain one or two sachets of oak

Package 2 – Day 14

- #3A – Wine Stabilizer
- #4 – Wine Clarifier
- Cleanser
- May contain #3B – Yeast Inhibitor
- May contain #5 – Wine Reserve bottle

Package 3 – Day 28

- Bottle Sanitizer
- Cleanser
- Wine Closures (12)
- Wine Bottle Labels (12)

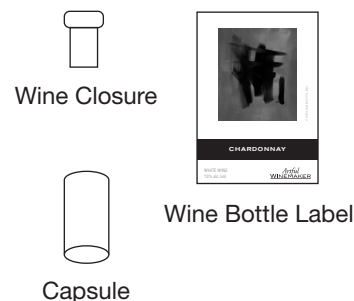

Other required equipment:

- Measuring cup
- Paper towels
- Scissors for opening packages
- Pitcher or large bowl
- Standard 750mL wine bottles (12)
- Artful Winemaker – Personal Winemaking System (PWS)

Important Dates

| | | |
|---------------|--------------------|--|
| DAY 1 | Date: _____ | Assembly, Cleaning, Sanitizing, Mixing & Fermenting |
| DAY 14 | Date: _____ | Stabilizing & Clearing |
| | DAY 15 Date: _____ | Sediment Release |
| | DAY 16 Date: _____ | Sediment Release |
| | DAY 17 Date: _____ | Sediment Release |
| DAY 28 | Date: _____ | Bottling |

Be sure to write these important dates on your calendar and at the top of each section.

Where to make your wine?

You will need to decide where you will make your wine. The area you select should be clean, out of direct sunlight and at a stable room temperature of 65°- 80°F (18°- 27°C). Since you will be using water to clean and sanitize your Personal Winemaking System components during the process, we recommend making your wine near a source of water. During the winemaking process, it is normal for your wine to give off natural aromatics.

Date Started: _____

DAY 1

STAGE 1 | Assembly, Cleaning & Sanitizing

IMPORTANT: Remove all contents from the inside before starting, including the two cones. Keep the box to store the equipment that is not currently being used.

Equipment required for this step:

- | | | |
|------------------------------|---------------------|----------------------|
| • Adhesive Thermometer | • Lid | <i>Not included:</i> |
| • Personal Winemaking System | • Handle | • Measuring cup |
| • Spigot | • Two-part Air Lock | • Paper towels |
| • Day 1 Package | • Spoon/Opener | |

- Remove the protective backing on the adhesive thermometer and attach it vertically on the front of the system in the outlined rectangle. **1**
- Make sure the red semicircular seal is positioned properly in the spigot opening on the front of the system before attaching the spigot. **2**
- Assemble the spigot on the system. Ensure the spigot is in the OFF position. Line up the #1 on the spigot collar with the inverted triangle on the face of the system and twist counter-clockwise to line up the #2 with the inverted triangle. **3**
- Add the contents of the cleanser to four (4) cups (one (1) litre) of warm tap water and stir to dissolve. Pour this solution into the system and add an additional four (4) cups (one (1) litre) of warm tap water. Stir with spoon end of spoon/opener to mix. Attach the lid securely by tightening down the handle until the line on the handle lines up with the line on the lid. Insert the bottom of the two-part air lock into the grommet in the lid. **4** Plug the small opening in the air lock with your thumb or finger and swish the solution for approximately one (1) minute to ensure that it *comes in contact with all surfaces including the underside of the lid*. Lift your thumb or finger frequently to release any pressure.
- Remove the bottom of the two-part air lock from the lid. Unscrew the handle and remove the lid. Insert the spoon/opener and two-part air lock (separate top and bottom of air lock) in the sanitizing solution, making sure that the solution comes into contact with all surfaces. Place the spoon/opener and air lock on a paper towel to allow them to drain. (It's okay for small drops of cleanser to remain on the surfaces of the components. The cleanser will not harm the wine.)
- Turn the spigot collar so that the #3 lines up with the inverted triangle on the face of the system. Open the spigot to allow a small amount of cleanser solution to drain out. **5** Dispose of the rest of the cleanser solution. Remove the spigot by turning the collar clockwise to match the #1 with the inverted triangle on the face of the system. Ensure that the spigot is in the ON position. Rinse the spigot with warm water. (Doing this is necessary, as the inner chamber of the spigot will not have any liquid in it until bottling time.) Place upside down on a paper towel along with the spigot to allow them to drain.

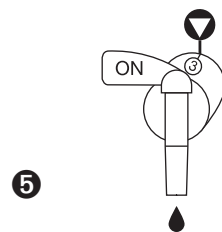
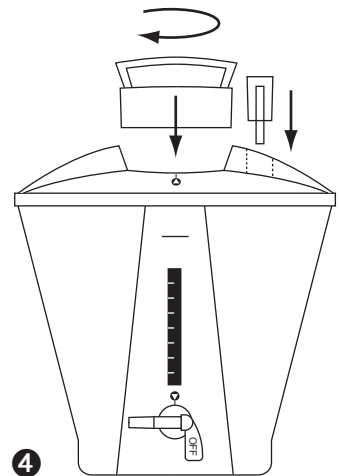
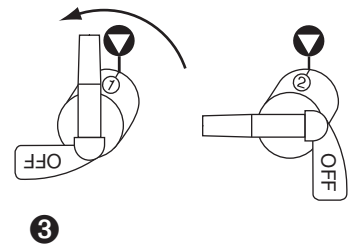
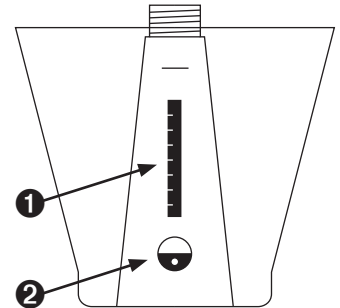

Date Started: _____

DAY 1

STAGE 2 | Mixing & Fermenting

Equipment required for this step:

- | | | |
|------------------------------------|---------------------|----------------------|
| • Personal Winemaking System (PWS) | • Spoon/Opener | <i>Not included:</i> |
| • Spigot | • Lid | • Measuring cup |
| • Base | • Handle | • Paper towels |
| • Premium Wine Kit box | • Two-part Air Lock | |

If your premium kit contains a sachet (or sachets) of oak, now is the time to prepare the oak prior to adding the sachet(s) to the juice. The oak is packaged in a permeable sachet and **should not be opened**. Place the oak sachet(s) in a cup (8 oz. or 250ml) of hot water and allow to soak completely. Set cup aside to steep until needed.

Assemble the spigot on the System. Ensure the spigot is in the OFF position. Line up the #1 on the spigot collar with the inverted triangle on the face of the system and twist counter-clockwise to line up the #2 with the inverted triangle. **6**

Place the system on the base so that the spigot is positioned above the indent. Lock in place using the switch located on the opposite end of the base. **7** *Note: The lock prevents the system from rotating.*

Puncture the perforated edges on the side of the Premium Wine Kit box. Place bag of grape juice into the box, positioning the spout firmly in the hole. Remove the lid from the bag of grape juice by holding the rigid part of the spout firmly with one hand and removing the cap, using the opener end of the opener as you would do when removing a bottle cap. Gently pour the juice into the system. Rinse the bag with a small amount of room-temperature water and add to the system.

If your style of wine contains oak, which you have set aside to steep, add the sachet of oak along with the water it has been soaking in, to the grape juice.

With the system placed on a level surface, *slowly* fill it up to the FILL line using *room-temperature* drinking water (65°- 80°F or 18°- 27°C). **Be careful not to overfill**. Mix well with spoon.

Check temperature on adhesive thermometer to ensure that it is in the 65°- 80°F (18°- 27°C) range. The light green bar on the thermometer strip will highlight the temperature of your juice. If the temperature falls in this range, you may proceed to the next step. If the juice is cooler or warmer, attach the lid securely by tightening down the handle until the line on the handle lines up with the line on the lid. Allow the juice to adjust to within this temperature range before proceeding.

Open **Packet #2 – Primary Wine Clarifier** and sprinkle into the juice. Stir vigorously with the spoon for several seconds to mix completely.

Rinse the spoon with water and allow to drain on a paper towel.

Open packet labeled **Yeast** and sprinkle on top of juice. *If your wine contains oak, be careful to sprinkle the yeast on the surface of the juice only, not on top of the oak sachet(s).* The yeast does not need to be stirred in.

Place lid on the system and tighten the handle into position. Fill the bottom of the two-part air lock half full of water and attach the lid. Push the assembled air lock into the grommet on the top of the lid and make sure it is secured firmly. **8** Place the PWS and base in a warm (65°- 80°F or 18°- 27°C), stable, flat location. It is important that the PWS is **not** in direct sunlight at any point during the next 28 days. *Note: The water in the two-part air lock may dissipate. Please check the level every 2 days and top up when necessary.*

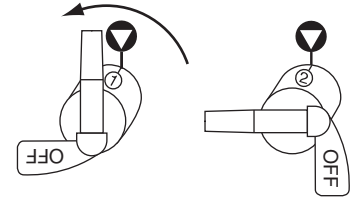

6

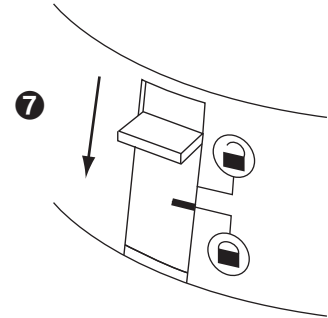

7

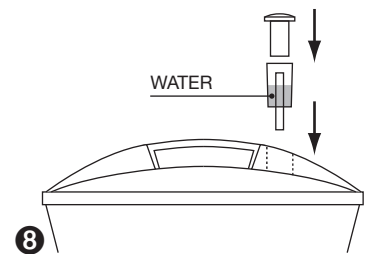

8

Date Started: _____

DAY 14

STAGE 3 | Stabilizing & Clearing

Equipment required for this step:

- Spoon/Opener
- Cone Seal
- Cone #1 – See imprint on base of cone
- Day 14 Package
- Not included:*
- Paper towels

Note: During the first 14 days of the fermentation, sediment has collected at the bottom. This next step will seal the sediment in a chamber away from your wine.

Put 32 cups (two gallons or eight (8) liters) of warm water into a clean sink and sprinkle the packet of cleanser into the water. Mix the solution until dissolved and the spoon is sanitized. Set spoon aside on a paper towel to drain. Immerse **Cone 1** and the cone seal in solution, rolling cone to ensure solution contacts all surfaces. Avoid contact with eyes. Attach seal onto Cone 1. **9** Allow to drain on a paper towel prior to next step. You do not have to rinse. You may now drain the cleanser solution from the sink.

Remove the lid by unscrewing the handle and lifting off the lid. Place it right side up on a paper towel.

If your wine contains any oak, carefully remove the oak sachet(s) from the wine now by using the slotted spoon. Dispose of the oak sachets. *Note: Please be careful not to disturb the layer of sediment at the bottom.*

Carefully lower sanitized Cone 1, with its attached seal, into the PWS and gently press into place. Without the lid, screw the handle down until the handle can no longer be tightened. **10** (It is normal for wine to come out of the holes at top of the cone during this procedure.)

Sprinkle **Packet #3A – Wine Stabilizer** into the wine and stir vigorously for one minute, reversing directions every five rotations, to dissolve. *Note: This process also helps to eliminate the fermented gases from your wine.*

If your premium wine kit contains a bottle labeled **#5 – Wine Reserve**, add it to the wine now and stir vigorously for one minute, reversing direction every five rotations to mix completely.

If your kit contains a **Packet #3B – Yeast Inhibitor**, add it to the wine now and stir vigorously for one minute, reversing direction every five rotations to mix completely.

Add **Packet #4 – Wine Clarifier** into wine and stir vigorously for one minute, reversing direction every five rotations to mix completely.

Rinse the spoon with water and allow to dry on a paper towel.

Unscrew the handle and replace lid, making sure the air lock is in place and still half full of water. Reattach handle to hold lid securely in place. *Note: It is normal for the air lock to bubble when you tighten the lid.*

Position the PWS and base on an elevated surface (like a counter top) in preparation for the upcoming bottling step, and leave it to clear for 14 days.

Make sure the system is not in direct sunlight.

Starting on the next day, and during the following three days, unlock the system from the base and rotate it back and forth three times to release any sediment that has accumulated on its walls. **11**

DAY 15 Date

DAY 16 Date

DAY 17 Date

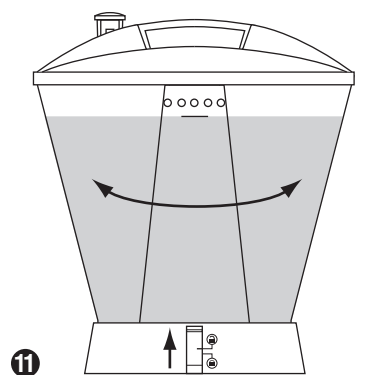
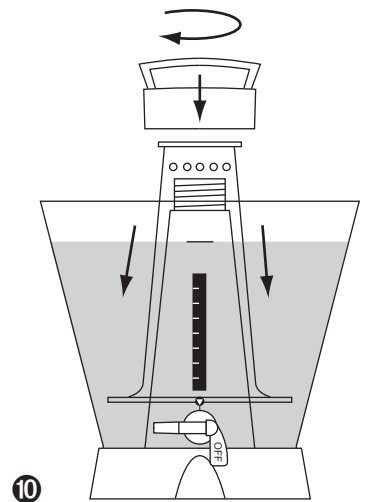
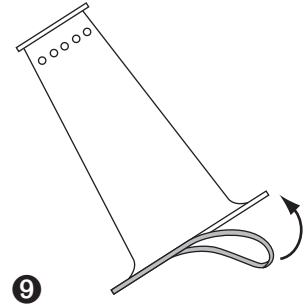

Date Started: _____

DAY 28

STAGE 4 | Bottling

At this stage, your wine is ready to be bottled. If it is not convenient to bottle on this exact date, the wine can be left in the system for a *maximum* of two to three days longer, if necessary.

Equipment required for this step:

- | | | |
|--|------------------|------------------------------------|
| • Spoon/Opener | • Cone Seal | <i>Not included:</i> |
| • Cone #2 – See <i>imprint</i> on base of cone | • Funnel | • Paper towels |
| | • Day 28 Package | • Pitcher or large bowl |
| | • Capsules | • Standard 750mL wine bottles (12) |

IMPORTANT: Move your PWS to the edge of a counter, with the spigot over the edge, to prepare for bottling. If the sediment has been disturbed when moving your wine, allow the system to sit for one hour so that the sediment falls to the bottom before proceeding to the next step.

- To sanitize wine closures, dissolve packet labeled **Bottle Sanitizer** into eight (8) cups ($\frac{1}{2}$ gallon or two (2) liters) of cool water in a pitcher or large bowl. *Note: the bottle sanitizer contains sulphites.* Submerge wine closures in solution for one minute. Remove wine closures and allow to drain on a paper towel.
- Using the funnel, take this solution and evenly divide it between the 12 bottles for sanitization. Seal bottle with a wine closure and shake, ensuring all inside surfaces come into contact with the sanitizing solution. Dispose of the sanitizing solution from each bottle and set the bottles aside for filling later. *Note: If you plan to consume your wine immediately, rinse out sanitizing solution with water prior to bottling. If you prefer to cellar your wine up to 6 months, do not rinse the bottles. The bottle sanitizer will protect your wine.*
- Put 32 cups (two gallons or eight (8) liters) of warm tap water in a clean sink and sprinkle packet of cleanser into the water. Mix the solution with the spoon for approximately one minute. Immerse **Cone 2** and the separated cone seal in solution, rolling the cone and seal to ensure solution contacts all surfaces. Attach seal to Cone 2. **12** Allow to drain on a paper towel. *Note: This solution can be used to clean all your components after bottling.*
- To prepare for bottling, unscrew handle and remove lid. Carefully lower sanitized Cone 2 into the system until it contacts the sides near bottom. Without the lid, slowly screw the handle down until it reaches the stopped position and it will not turn any further. **13** *Note: Be careful not to disturb the layer of sediment.*
- Prepare the spigot for bottling by rotating the collar until the #3 matches up with the inverted triangle on the face of the system. Drain and discard the first 2 ounces of wine to eliminate any sediment in the spigot chamber. Put each bottle under the spigot mouth, raising the bottle up so that the spigot mouth is inside the mouth of the bottle. Slightly angle the bottle to allow the wine to flow down the inside walls of the bottle. **14** (*Hint: The flow speed of the wine can be controlled by slowly moving spigot rotator from full OFF to full ON.*) Fill bottles with wine leaving 1-1½ inches (2 ½-4 cm) of headspace between top of wine and top of bottle. **15**
- Insert wine closure after filling each bottle by pushing the stopper firmly into opening at top of bottle. Ensure the plastic cap is in contact with the top of the bottle and no space is visible between the plastic cap and the top of the bottle.

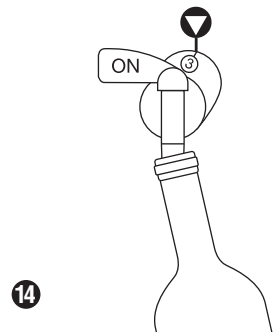
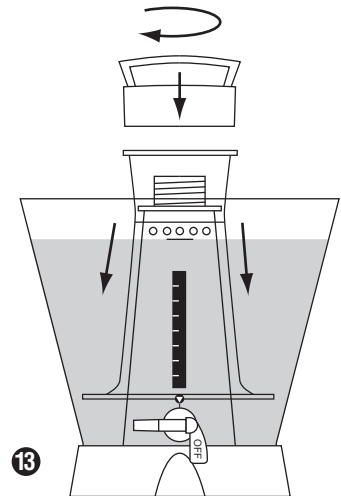
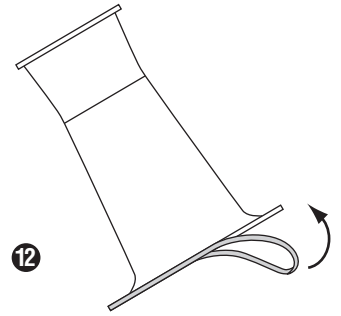

- Place capsule on clean, dry bottle tops after wine closures are in place. Using your hands, squeeze the capsules onto the bottles and wine closures.

 - Date and sign your wine bottle labels.

 - Apply labels to each bottle by peeling off protective backing, positioning at desired location on bottle, pressing down from the center and smoothing to the outside edges to eliminate any bubbles.
-

Your wine is ready to savour immediately after bottling! However, to achieve the best taste and bouquet results, we recommend allowing your wine to age at least another two weeks in the bottle before enjoying. We recommend that you consume all bottles within 6 months. White and blush wines will benefit from being chilled in the refrigerator prior to drinking. ENJOY!

CLEANING & STORING YOUR PERSONAL WINEMAKING SYSTEM

- It is important to clean your system and its components completely before using it again and storing it for future use.
- All items should be disassembled and rinsed with warm water to remove any debris from the winemaking process. Please ensure seals are all carefully cleaned so that no wine sediment remains.
- Once this has been done, all components can be thoroughly handwashed with a mild dish detergent or the cleanser from Stage 4 and a non-abrasive dishcloth.
- Once all parts are washed, completely rinse off any soap residue with hot water.
- Hand dry all parts with paper towel or allow to air dry completely before putting them away in their original box.
- Make sure you sanitize your Personal Winemaking System every time you craft wine.

NEED HELP WITH THE WINE MAKING PROCESS?

There are 3 ways you can reach us:

visit us on the web at www.ArtfulWinemaker.com/FAQ

or e-mail us at help@ArtfulWinemaker.com

or if you prefer direct assistance or more help, please call our toll free number **1-800-983-6671**

Artful
WINEMAKER
PERSONAL WINEMAKING SYSTEM

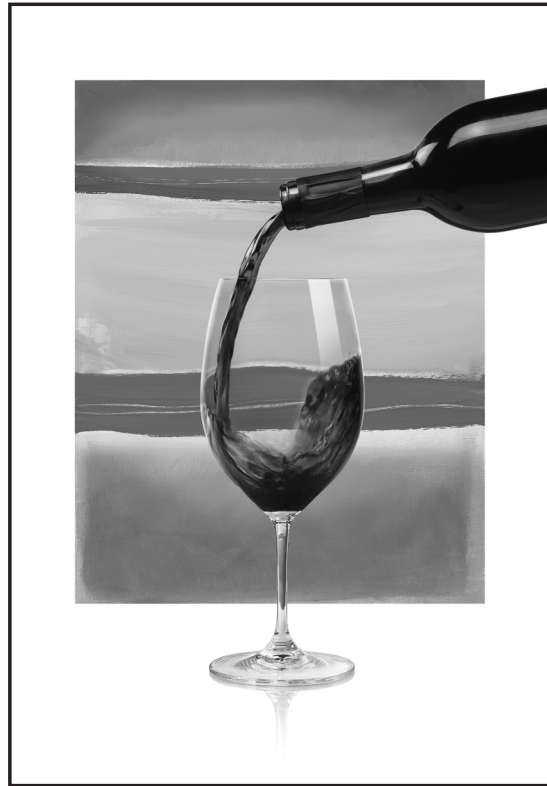

To order your next Artful Winemaker varietal,
visit ArtfulWinemaker.com